

The information in this document is subject to change without notice and should not be construed as a commitment by ABB. ABB assumes no responsibility for any errors that may appear in this document.

Except as may be expressly stated anywhere in this document, nothing herein shall be construed as any kind of guarantee or warranty by ABB for losses, damages to persons or property, fitness for a specific purpose or the like.

In no event shall ABB be liable for incidental or consequential damages arising from use of this document.

This document and parts thereof must not be reproduced or copied without ABB's written permission, and contents thereof must not be imparted to a third party nor be used for any unauthorized purpose. Contravention will be prosecuted.

Additional copies of this document may be obtained from ABB at its then current charge.

© Copyright 2022 ABB ALL right reserved.

ABB Engineering (Shanghai) Ltd
No.4528, Kangxin Highway,Kangqiao Town
Pudong New District, Shanghai, 201319
P.R.China

Latest revision:			Lab/Office: RA/RDP	CRB1300 COPYRIGHT PAGE	Status: Approved	Plant: = Location: + Sublocation: +
					Document no. 3HAC080868-003	Rev. Ind 00
Prepared by, date: CNXIDEN3	Approved by, date: CNJOHAU					

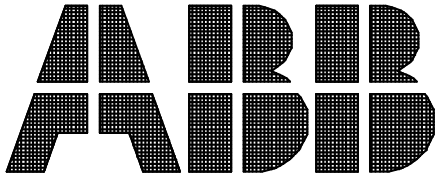

Description : CRB1300
Drawing number : 3HAC080868-003
Drawing version : 00
Date :

Customer :
Year of construction :
:
:
:
:
:
:
:
:
:
:

Drawn by : CNXIDEN3
Number of pages : 17
:
:
:
:
:
:

Latest revision:			Lab/Office: RA/RDP	CRB1300 TITLE PAGE	Status: Approved	Plant: = Location: + Sublocation: +
					Document no. 3HAC080868-003	Rev. Ind 00
Prepared by, date: CNXIDEN3	Approved by, date: CNJOHAU					

We reserve all rights in this document. No part of this document may be reproduced, stored in a retrieval system, or transmitted in any form or by any means, electronic, mechanical, photocopying, recording, or by any information storage and retrieval system, without express authority in writing from ABB. © Copyright 2002 ABB

Valid for:

This circuit diagram is valid for the following cable harness & board unit assemblies:

Cable harness for CRB1300:

3HAC067161-006 Main Harness,S,Basic+Air+C1+C2+C3

3HAC067161-009 Main Harness,M,Basic+Air+C1+C2+C3

3HAC067161-012 Main Harness,L,Basic+Air+C1+C2+C3

3HAC067163-001 Brake Release Unit

3HAC081729-004 Process Hub, Basic+Air+C1+C2+C3

Board unit for IRB1300:

3HAC065316-001 SMB Unit

Latest revision:			Lab/Office: RA/RDP	CRB1300 VALID FOR	Status: Approved	Plant: = Location: + Sublocation: +	Rev. Ind	Page 4
					Document no. 3HAC080868-003	00	Next 5 Total 17	
Prepared by, date: CNXIDEN3	Approved by, date: CNJOHAU							

2022-04-10 First version Ver00

We reserve all rights in this document. No part of this document may be reproduced, stored in a retrieval system, or transmitted in any form or by any means, electronic, mechanical, photocopying, recording, or by any information storage and retrieval system, without express authority in writing from ABB. © Copyright 2002 ABB

Latest revision:	
Prepared by, date: CNXIDEN3	Approved by, date: CNJOHAU



Lab/Office:
RA/RDP

CRB1300
REVISION INFORMATION

Status:	Plant: =
Approved	Location: +
	Sublocation: +

Document no.	Rev. Ind	Page
3HAC080868-003	00	5
		Next 6
		Total 17

Note
 1: How to operate the leadthrough unit will be described in product manual.

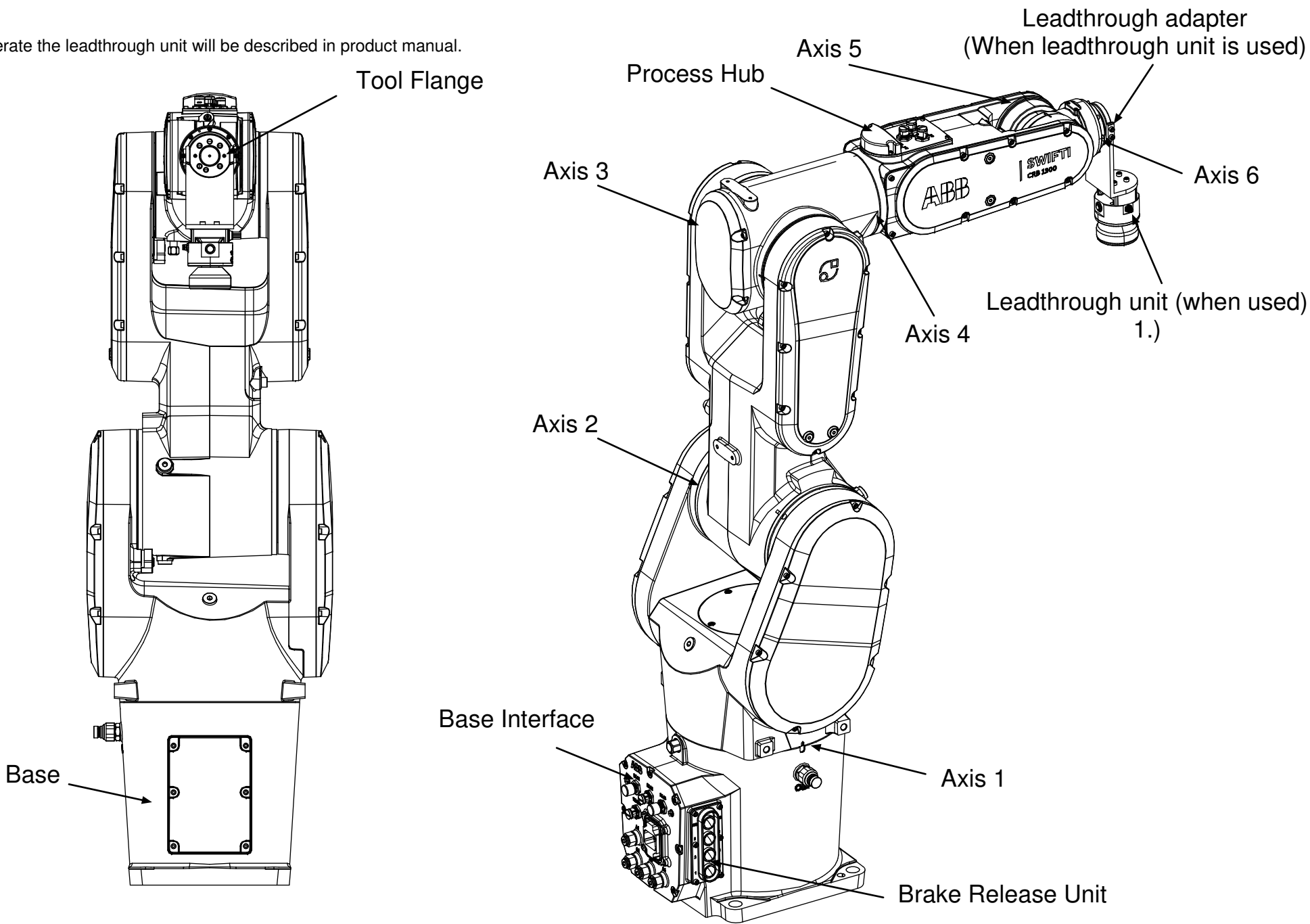

We reserve all rights in this document, in the information contained hereon and in the reproduction thereof. All rights of disclosure to third parties without express authority is strictly forbidden. © Copyright 2002 ABB

Latest revision:

Prepared by, date: CNXIDEN3 Approved by, date: CNJOHAU

ABB Lab/Office: RA/RDP

CRB1300
 SYSTEM OVERVIEW

Status: Approved	Plant: = Location: + Sublocation: +	Rev. Ind	Page 6
Document no. 3HAC080868-003	00	Next 7	Total 17

Note

1: Further information about the lamp can be found in product manual.

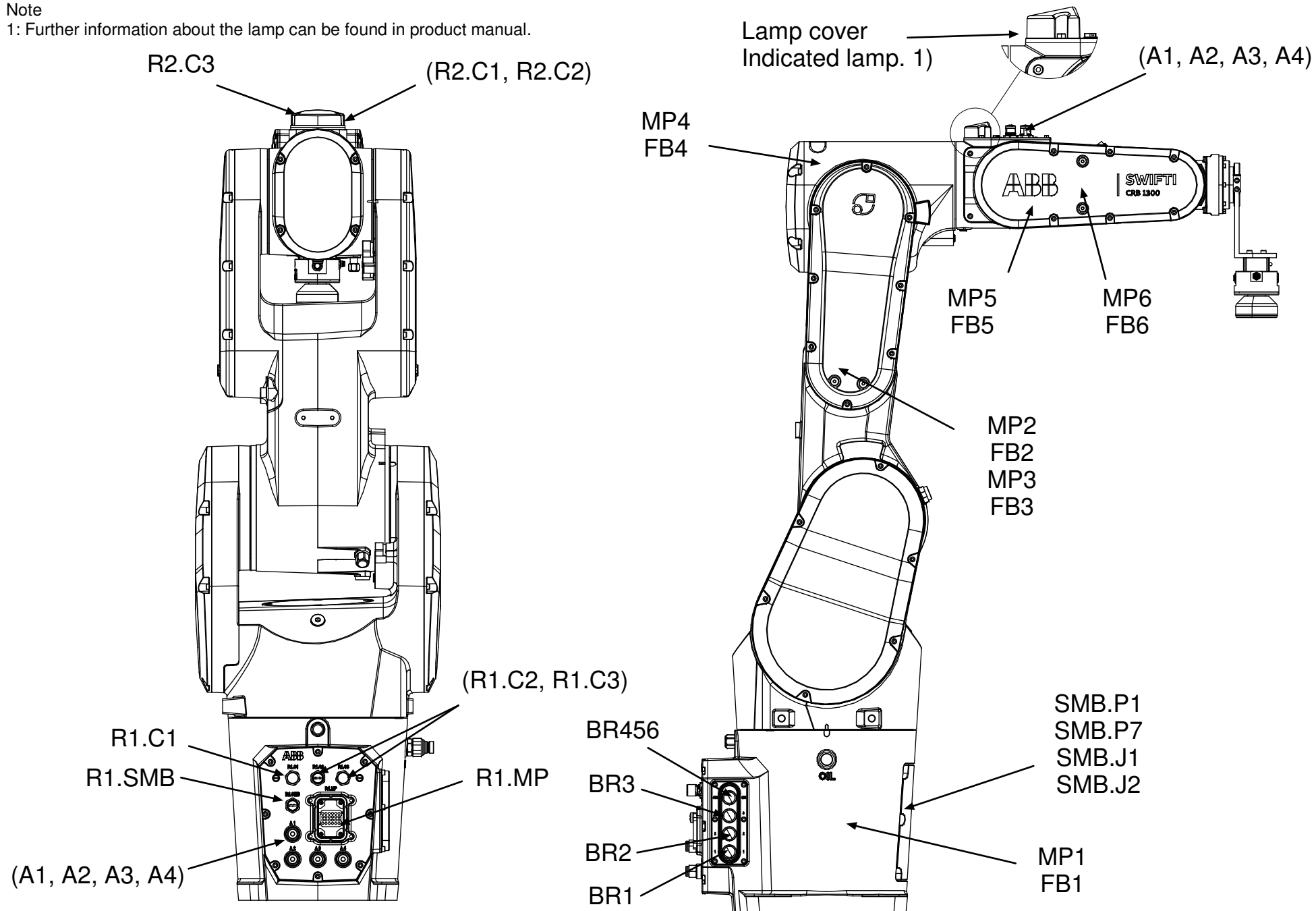

Latest revision:
 Prepared by, date: CNXIDEN3
 Approved by, date: CNJOHAU

ABB	Lab/Office: RA/RDP	CRB1300 CONNECTION POINT LOCATION

Status: Approved	Plant: Location: Sublocation:	= + +
Document no. 3HAC080868-003	Rev. Ind 00	Page 7 Next 8 Total 17

we reserve all rights in this document. No part of this document may be reproduced, stored in a retrieval system, or transmitted in any form or by any means, electronic, mechanical, photocopying, recording, or by any information storage and retrieval system, without express authority in writing from ABB. © Copyright 2002 ABB

Brake Release Unit

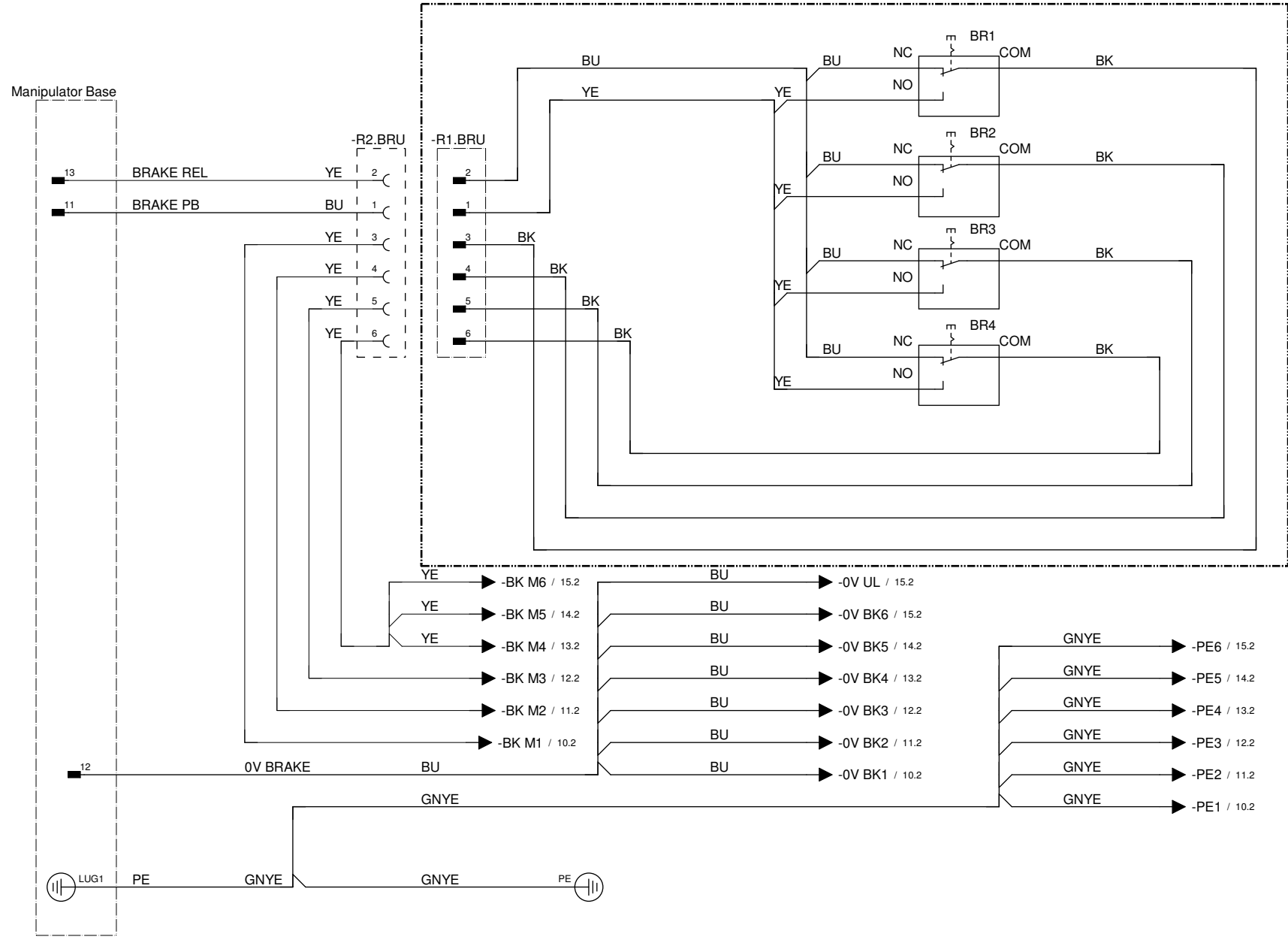

We reserve all rights in this document and the information contained herein. Reproduction, distribution, or disclosure to third parties without express authority is strictly forbidden. © Copyright 2002 ABB

Latest revision:		Lab/Office: RA/RDP	CRB1300 BRAKE RELEASE UNIT	Status:	Plant: =	
				Approved	Location: +	
Prepared by, date: CNXIDEN3	Approved by, date: CNJOHAU			Document no.	Rev. Ind	Page 8
				3HAC080868-003	00	Next 9 Total 17

Manipulator Base

-R1.SMB

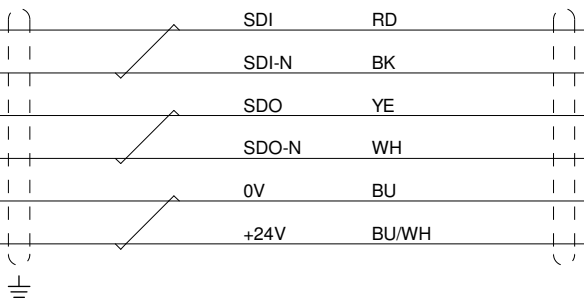
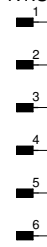

-SMB

-SMB.P7

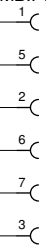

-SMB.P1

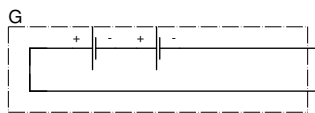
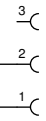

Latest revision:
Prepared by, date: CNXIDEN3 | Approved by, date: CNJOHAU



Lab/Office:
RA/RDP

CRB1300
SERIAL MEASUREMENT BOARD

Status:
Approved

Plant: =
Location: +
Sublocation: +

Document no.
3HAC080868-003

Rev. Ind	Page 9
00	Next 10
	Total 17

We reserve all rights in this document, and no information contained herein may be reproduced, stored in a retrieval system, or transmitted in any form or by any means, electronic, mechanical, photocopying, recording, or by any information storage and retrieval system, without express authority in writing from ABB. © Copyright 2002 ABB

We reserve all rights in this document. No part of this document may be reproduced, stored in a retrieval system, or transmitted in any form or by any means, electronic, mechanical, photocopying, recording, or by any information storage and retrieval system, without express written permission from ABB. © Copyright 2002 ABB

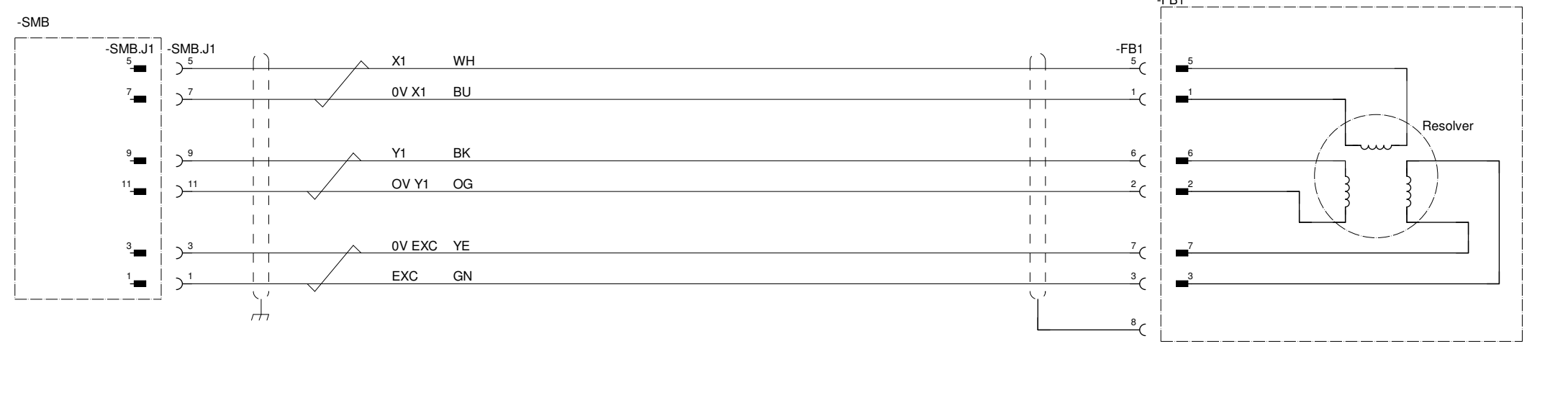
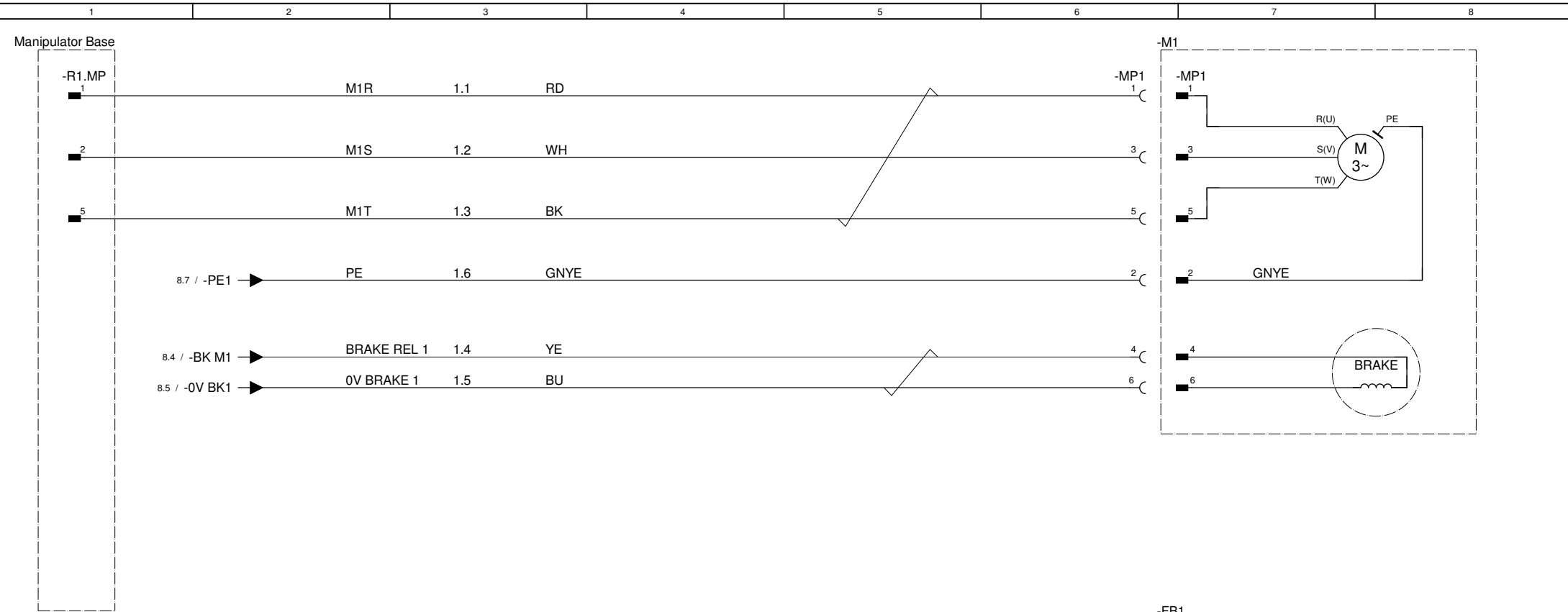

Latest revision:

Prepared by, date: CNXIDEN3 | Approved by, date: CNJOHAU

ABB	Lab/Office: RA/RDP	CRB1300 AXIS 1

Status: Approved	Plant: Location: Sublocation: +	Rev. Ind 00	Page 10 Next 11 Total 17
Document no. 3HAC080868-003			

Manipulator Base

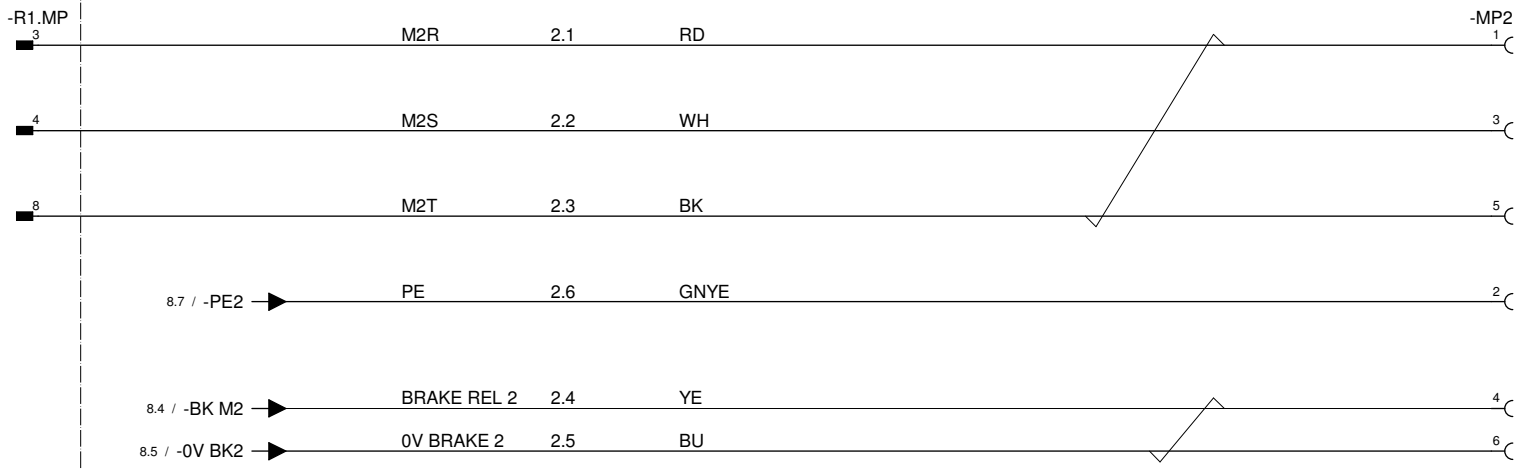

-M2

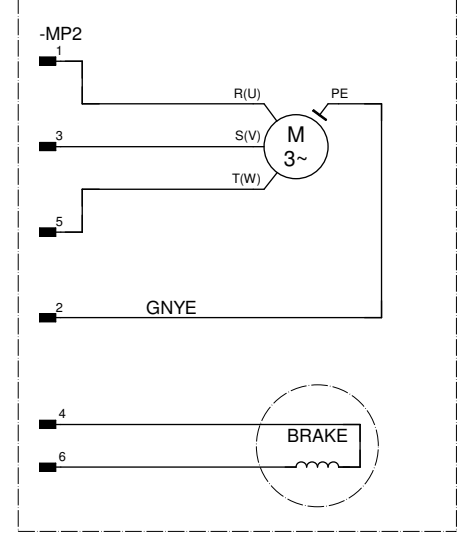

-SMB

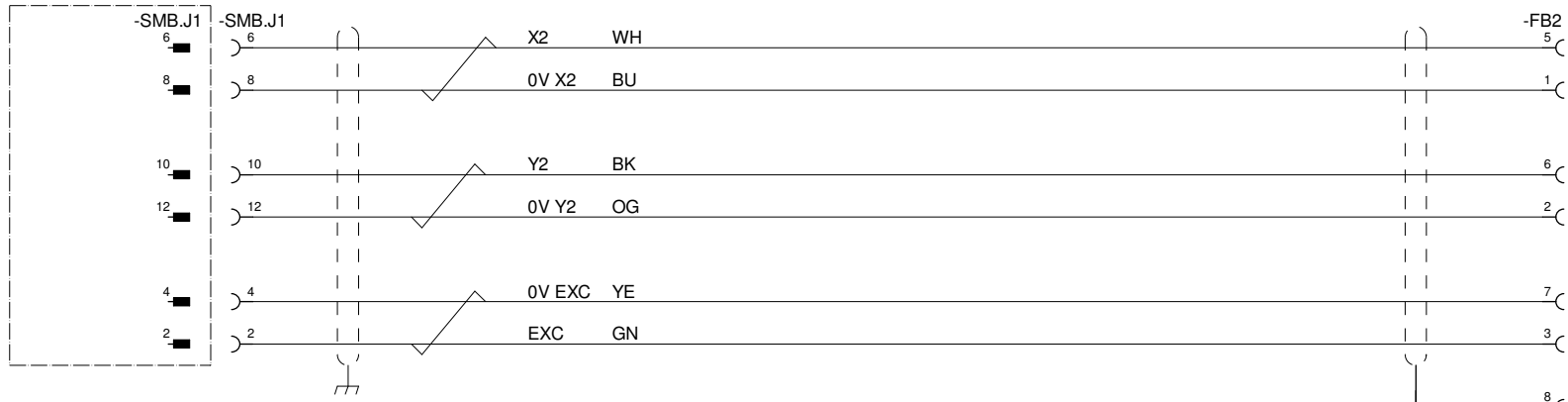

-FB2

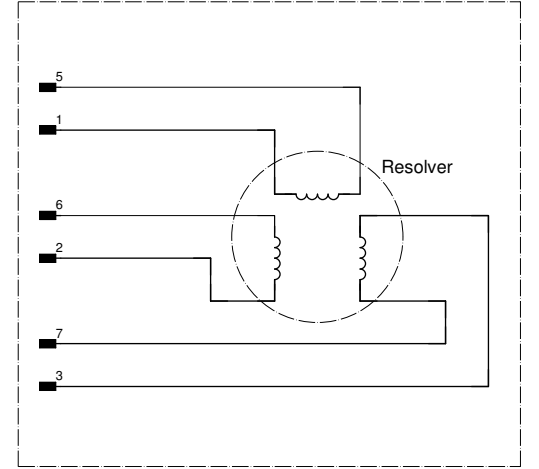

Latest revision:
 Prepared by, date: CNXIDEN3
 Approved by, date: CNJOHAU

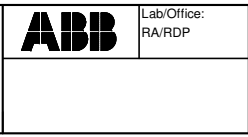

Lab/Office: RA/RDP
 CRB1300
 AXIS 2

Status: Approved	Plant: = Location: + Sublocation: +
Document no. 3HAC080868-003	Rev. Ind 00
	Page 11 Next 12 Total 17

We reserve all rights in this document. No part of this document may be reproduced, stored in a retrieval system, or transmitted in any form or by any means, electronic, mechanical, photocopying, recording, or by any information storage and retrieval system, without express written permission from ABB. © Copyright 2002 ABB

We reserve all rights in this document. No part of this document may be reproduced, stored in a retrieval system, or transmitted in any form or by any means, electronic, mechanical, photocopying, recording, or by any information storage and retrieval system, without express authority in writing from ABB. © Copyright 2002 ABB

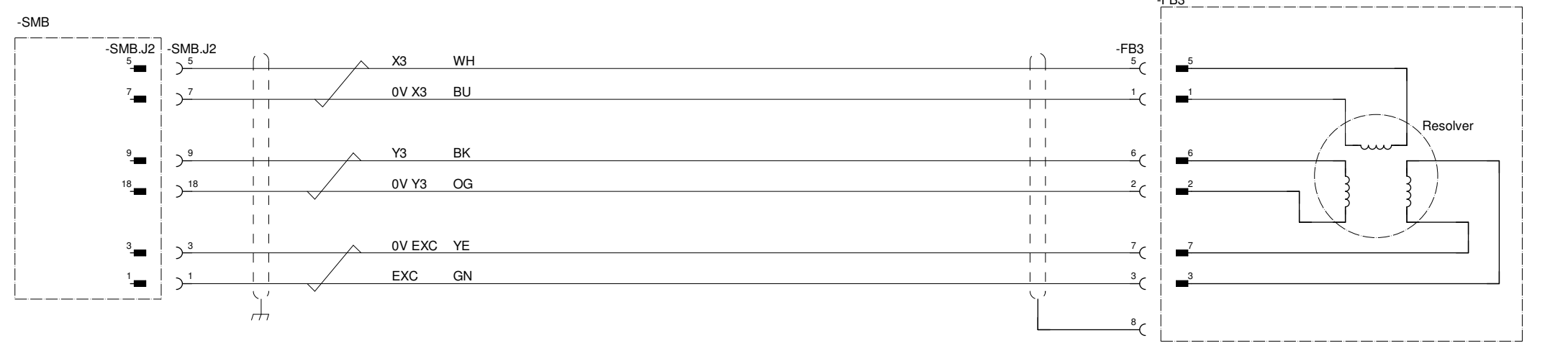
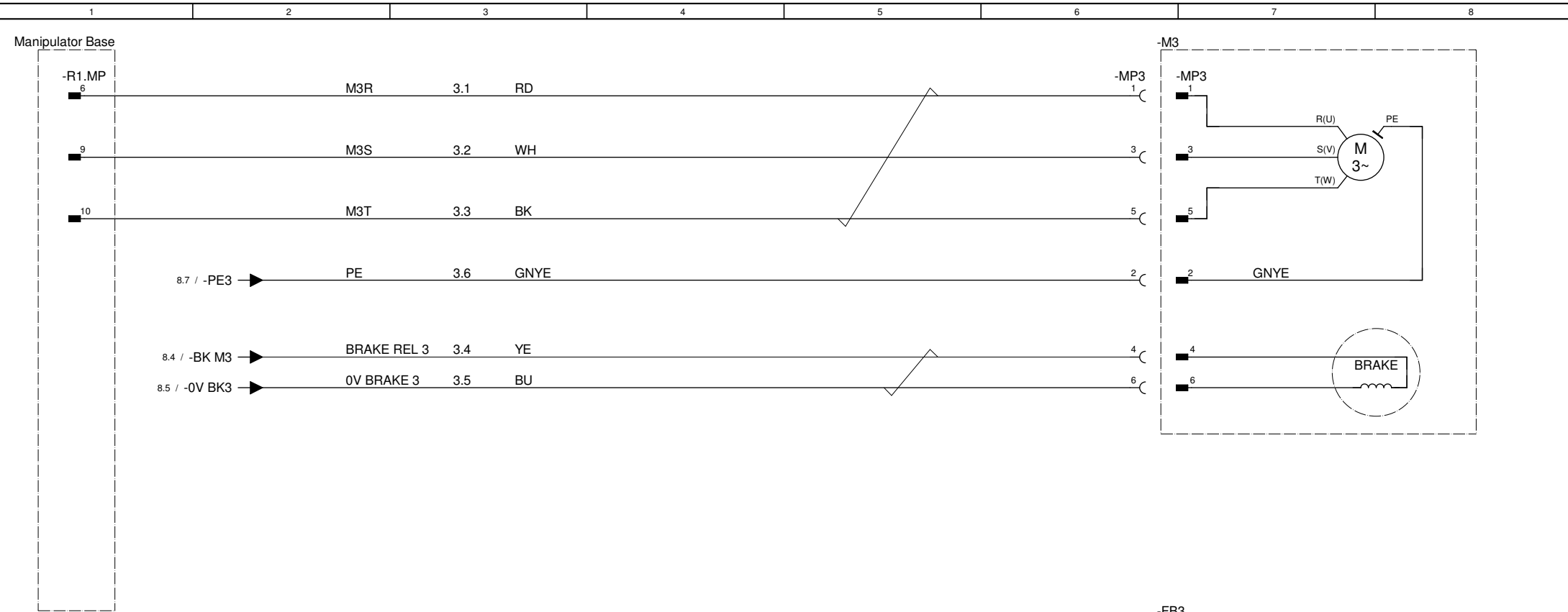

Latest revision:

Prepared by, date: CNXIDEN3 | Approved by, date: CNJOHAU

ABB Lab/Office: RA/RDP
 CRB1300
 AXIS 3

Status: Approved	Plant: = Location: + Sublocation: +
Document no. 3HAC080868-003	Rev. Ind 00
	Page 12 Next 13 Total 17

Manipulator Base

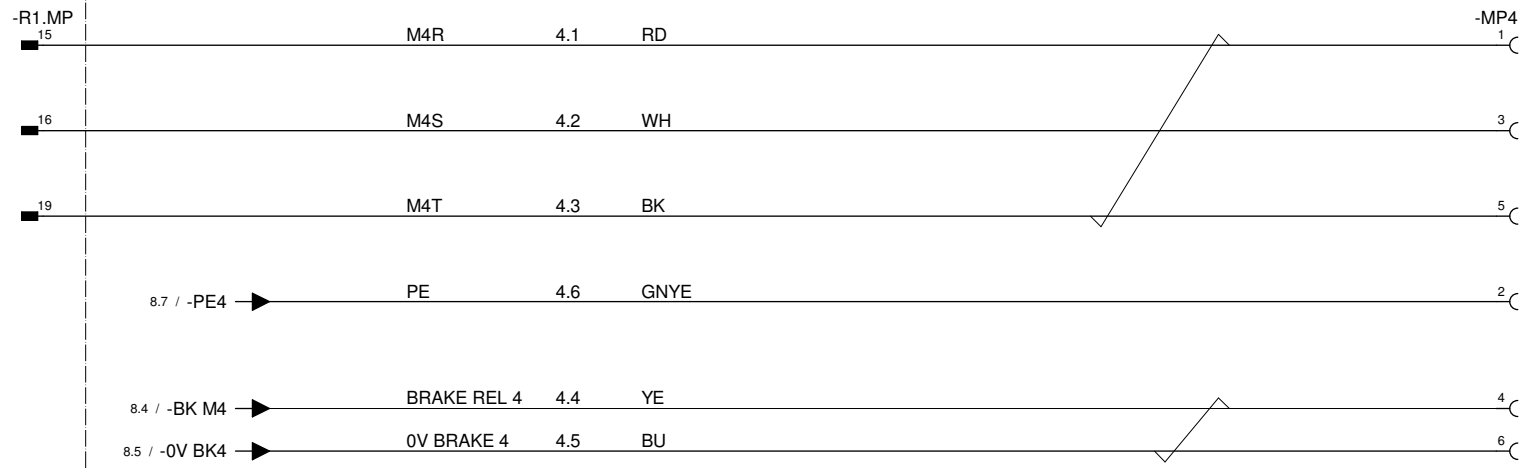

-M4

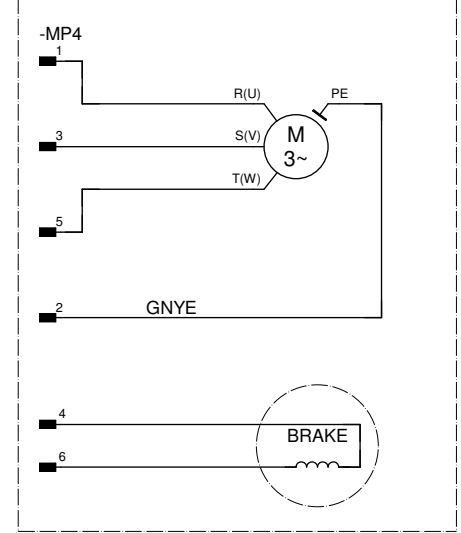

-SMB

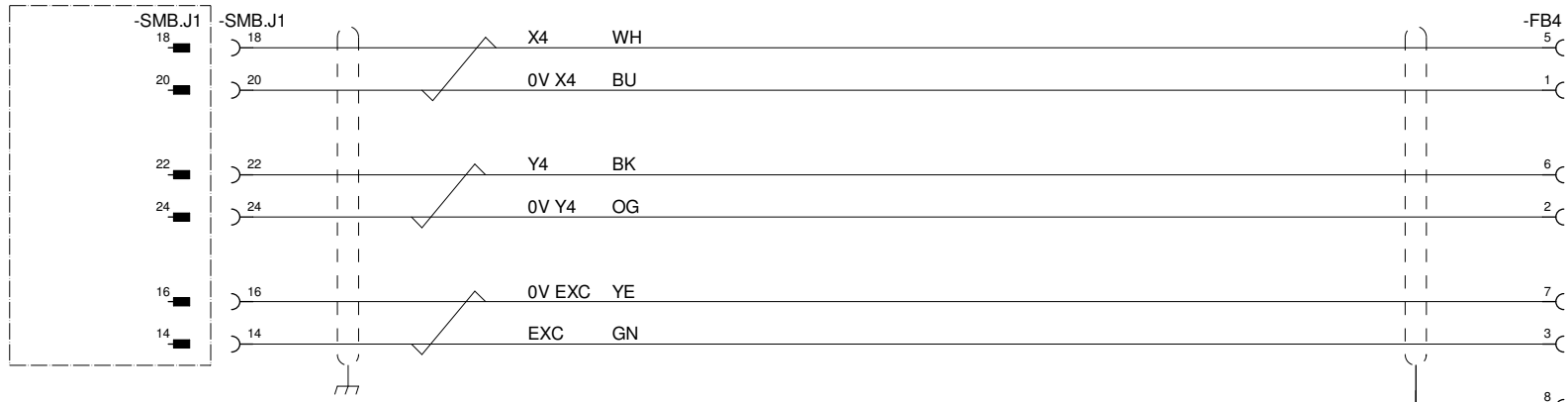

-FB4

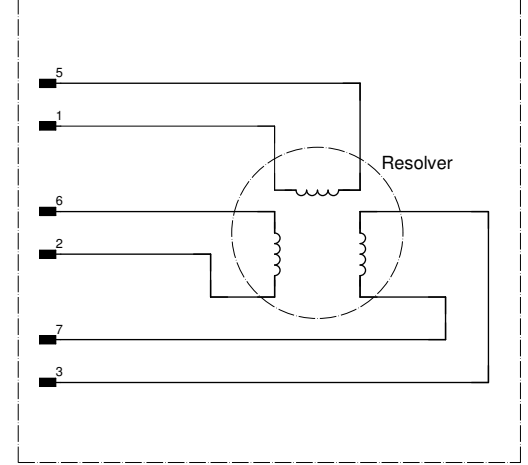

Latest revision:
Prepared by, date: CNXIDEN3 | Approved by, date: CNJOHAU

ABB Lab/Office: RA/RDP
CRB1300
AXIS 4

Status: Approved	Plant: = Location: + Sublocation: +
Document no. 3HAC080868-003	Rev. Ind 00
	Page 13 Next 14 Total 17

We reserve all rights in this document. No part of this document may be reproduced, stored in a retrieval system, or transmitted in any form or by any means, electronic, mechanical, photocopying, recording, or by any information storage and retrieval system, without express written permission from ABB. © Copyright 2002 ABB

Manipulator Base

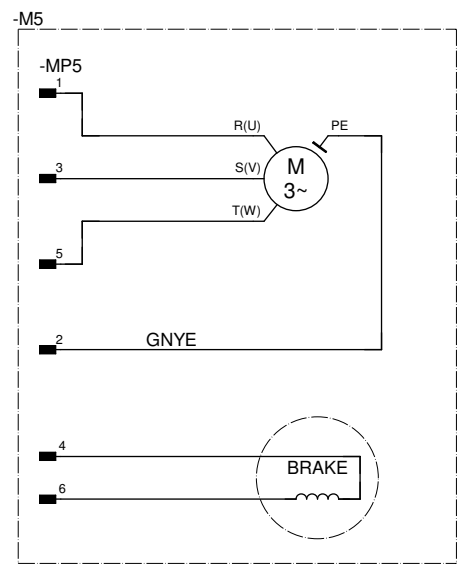
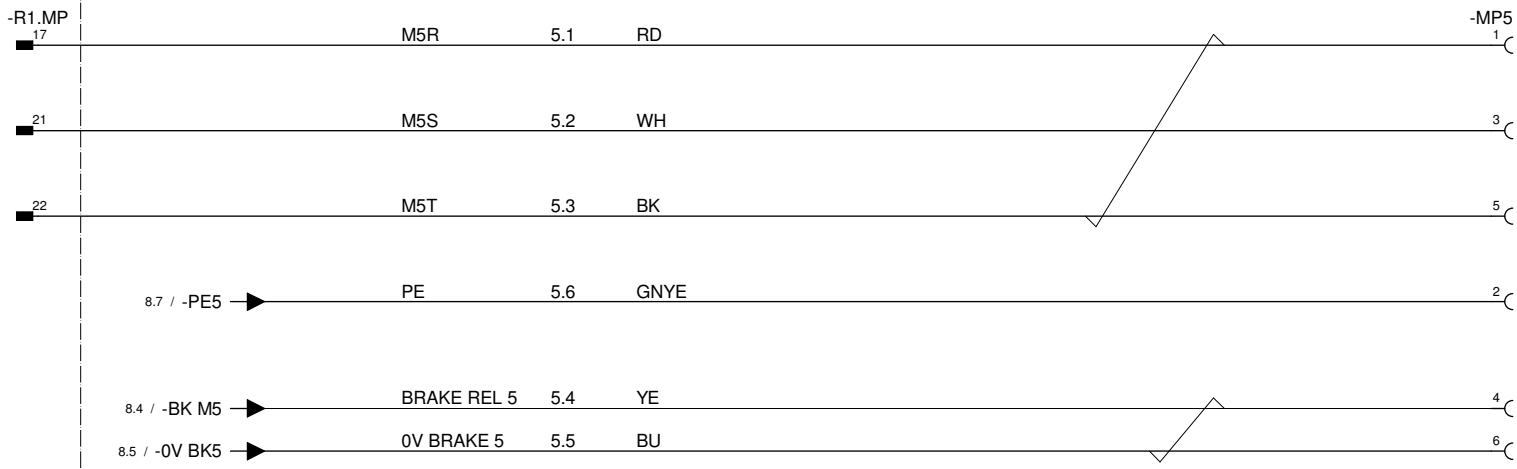

-SMB

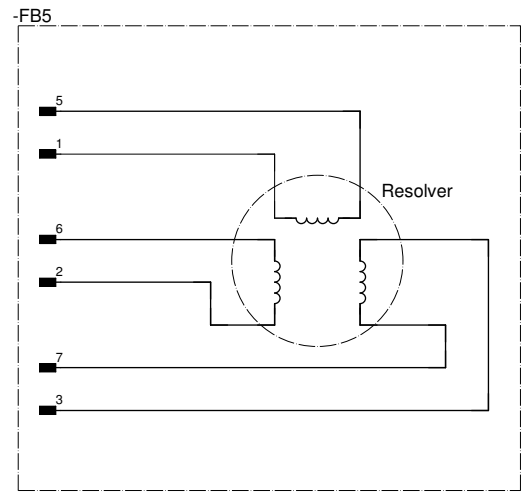
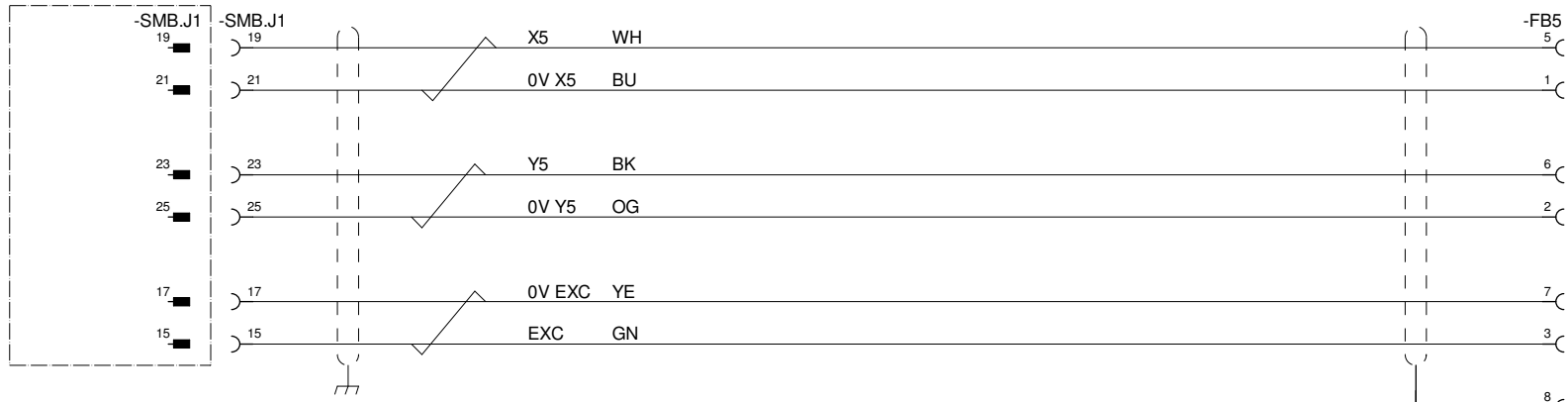

Latest revision:

Prepared by, date: CNXIDEN3 | Approved by, date: CNJOHAU

ABB Lab/Office: RA/RDP

CRB1300
AXIS 5

Status: Approved	Plant: = Location: + Sublocation: +
Document no. 3HAC080868-003	Rev. Ind 00
	Page 14 Next 15 Total 17

We reserve all rights in this document. No part of this document may be reproduced, stored in a retrieval system, or transmitted in any form or by any means, electronic, mechanical, photocopying, recording, or by any information storage and retrieval system, without express written permission from ABB. © Copyright 2002 ABB

We reserve all rights in this document. No part of this document may be reproduced, stored in a retrieval system, or transmitted in any form or by any means, electronic, mechanical, photocopying, recording, or by any information storage and retrieval system, without express written permission from ABB. © Copyright 2002 ABB

Manipulator Base

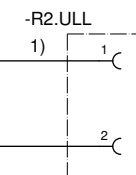
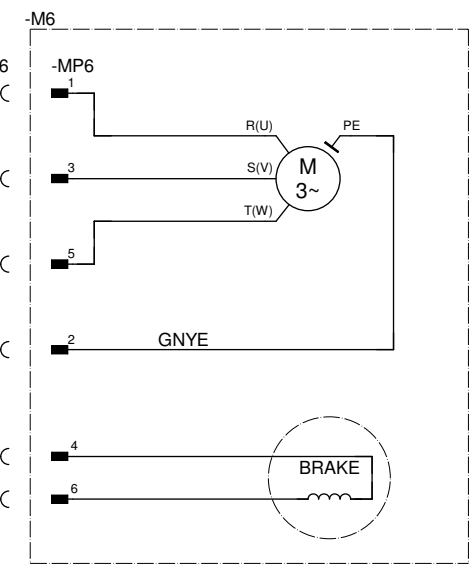
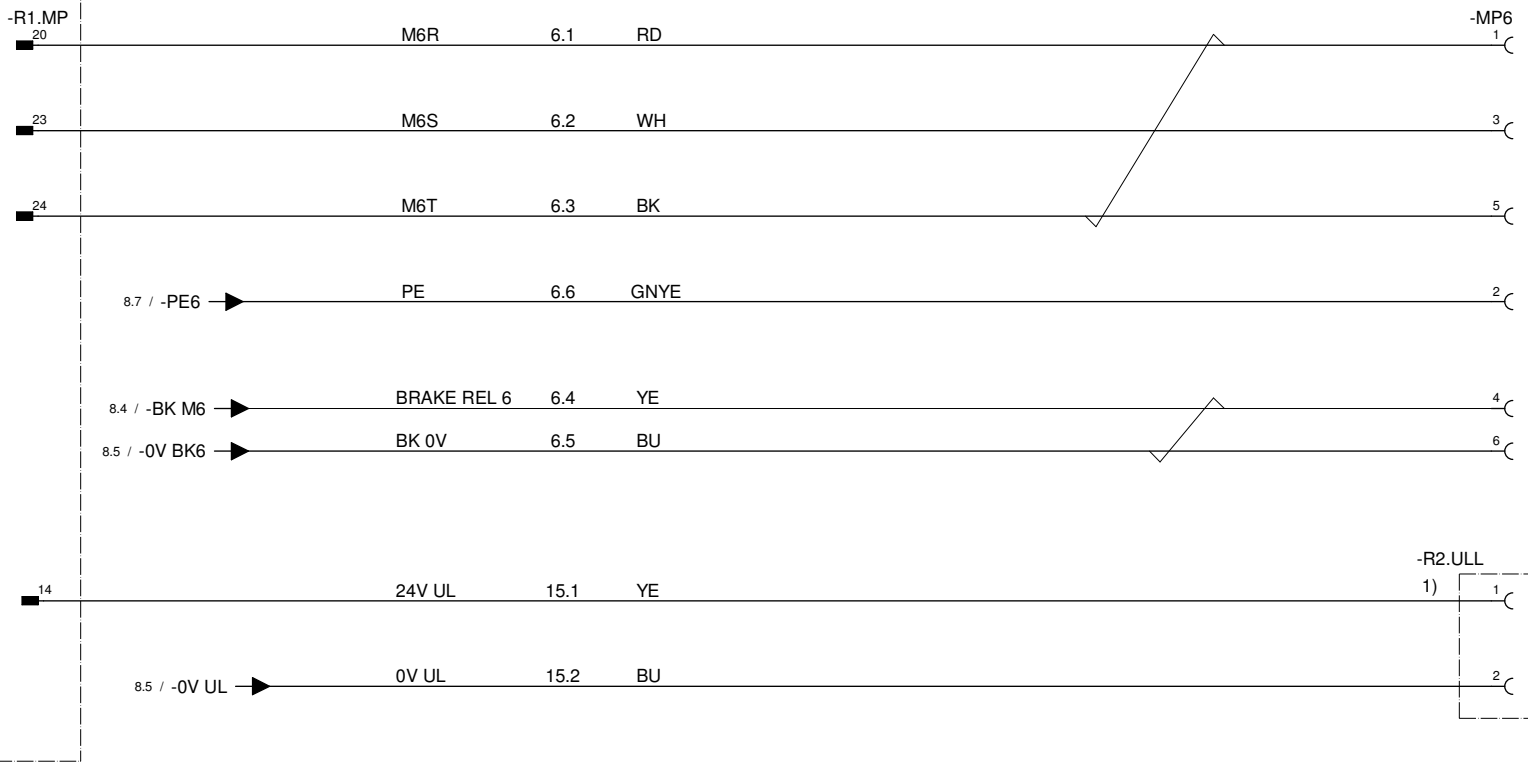

1) R2.ULL is only reserved for UL lamp.

-SMB

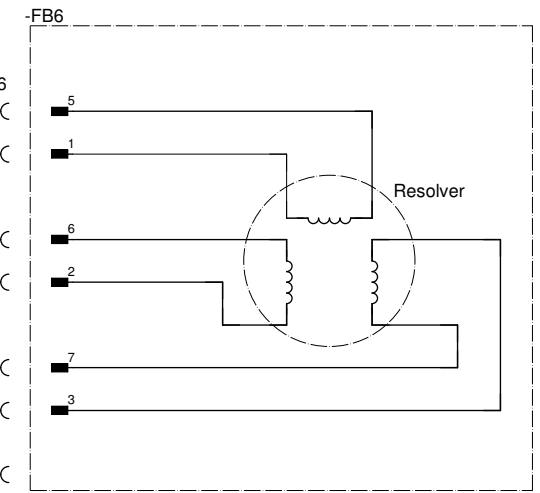
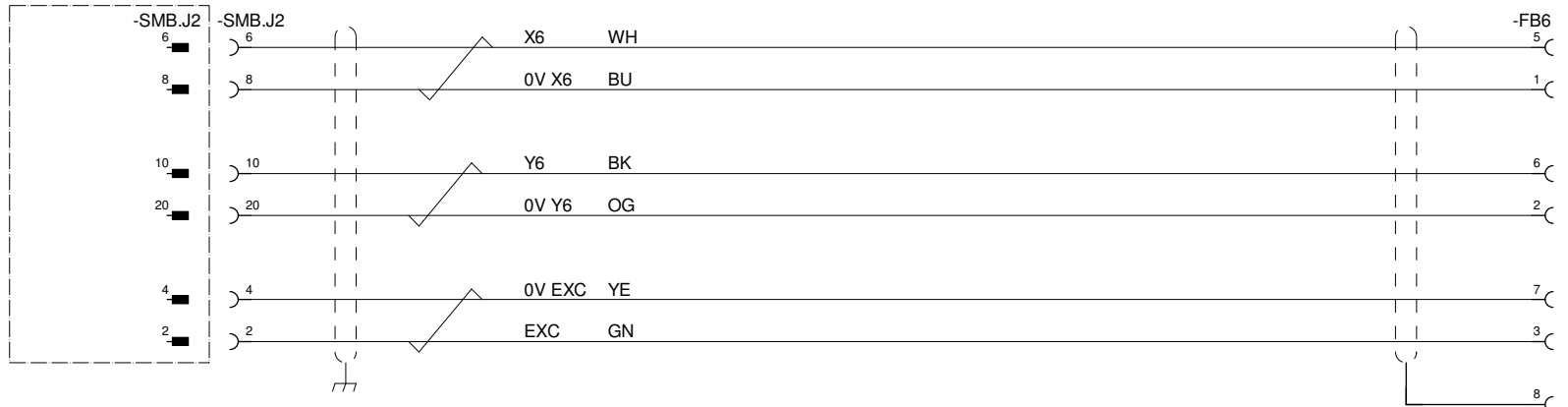

Latest revision:

Prepared by, date: CNXIDEN3 | Approved by, date: CNJOHAU

ABB Lab/Office: RA/RDP CRB1300 AXIS 6

Status: Approved
 Plant: = Location: + Sublocation: +
 Document no. 3HAC080868-003
 Rev. Ind 00 Page 15
 Next 16
 Total 17

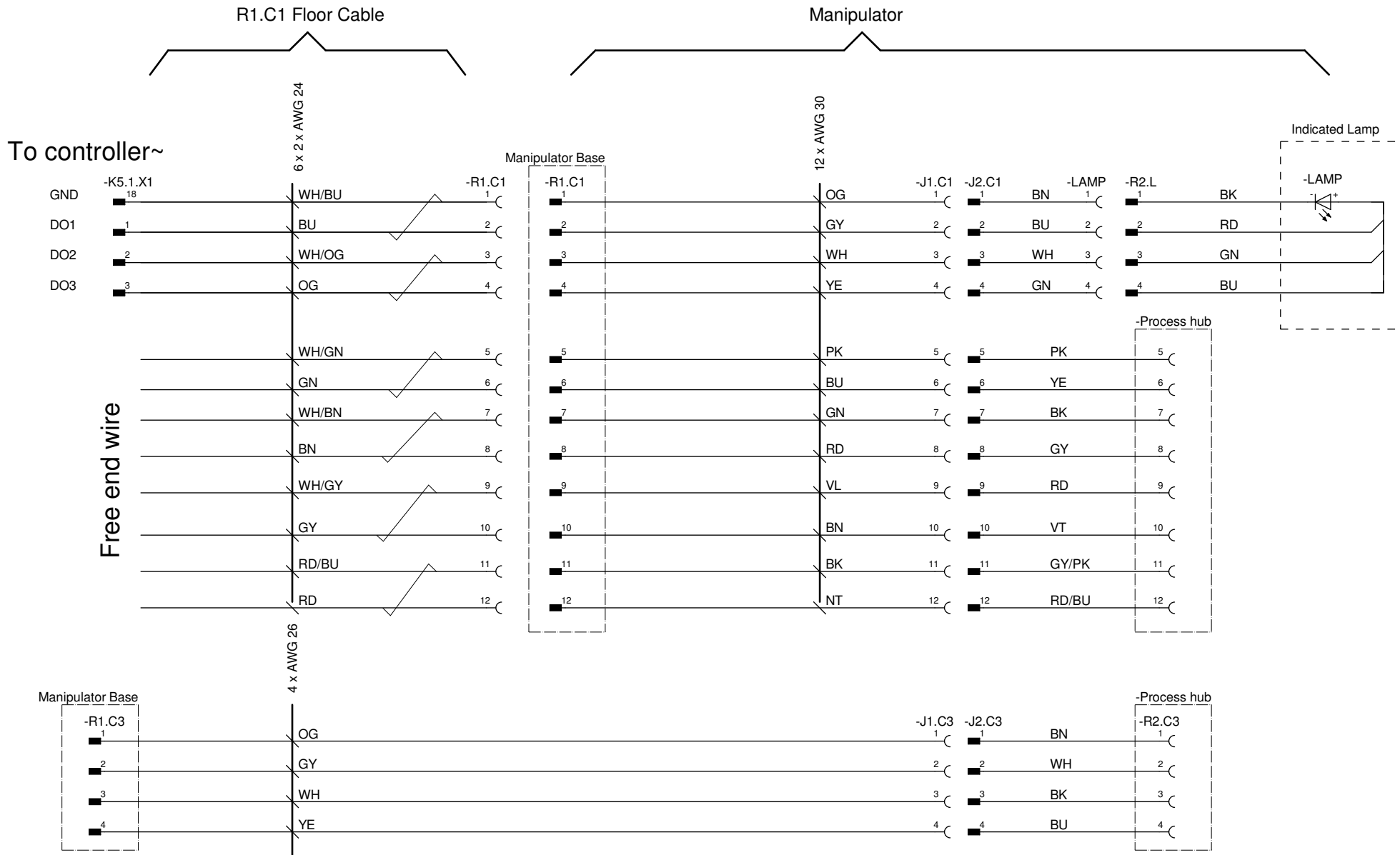

Note : 1) Maximum rating in each C1 wire: 30V, 1.5A. Stresses above the limitation may cause permanent damage to the manipulator.
 Note : 2) Maximum rating in each C3 wire: 42V DC or 25V AC, 4A. Stresses above the limitation may cause permanent damage to the manipulator

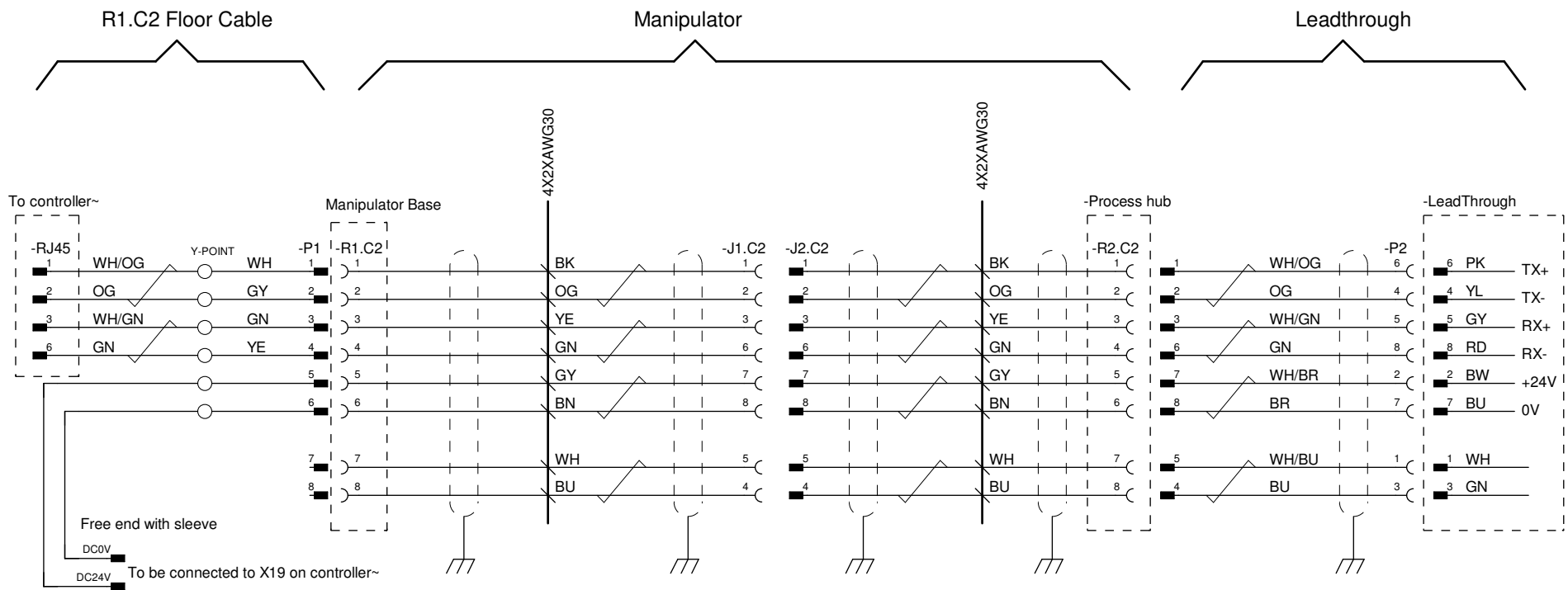

Note : 1): Ethernet cable connecting instruction 3HAC063936-005

Note : 2): Maximum rating in each C2 wire: 30V, 1A (when not using for Ethernet). Stresses above the limitation may cause permanent damage to the manipulator.

we reserve all rights in this document. No part of this document may be reproduced, stored in a retrieval system, or transmitted in any form or by any means, electronic, mechanical, photocopying, recording, or by any information storage and retrieval system, without express authority in writing from ABB. © Copyright 2008 ABB

Latest revision:		ABB	Lab/Office: RA/RDP	CRB1300 ETHERNET CONNECTION	Status: Approved	Plant: Location: Sublocation:	= + +
			Document no. 3HAC080868-003		Rev. Ind 00	Page 17 Next Total 17	
Prepared by, date: CNXIDEN3	Approved by, date: CNJOHAU						